

# DECADE

**Architectural bollard  
for circulation areas  
and public spaces subject to vandalism.**

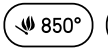

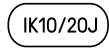

## FEATURES:

- Bollard body and head in aluminium treated against corrosion
- Acrylic reflector
- Polycarbonate diffuser
- Polyester black powder-coated finish
- CCT 3000K, CRI min. 80
- Stainless steel vandal-resistant black screws (tool supplied)
- Standard anchoring: code 9885 0001
- 3-year guarantee
- RAL 9005 ●

## OPTIONS AVAILABLE ON REQUEST:

- Reinforced anchoring for embedding into concrete (VK25)  
code : **9885 0002**

Decade bollard  
Code : 8500 2300

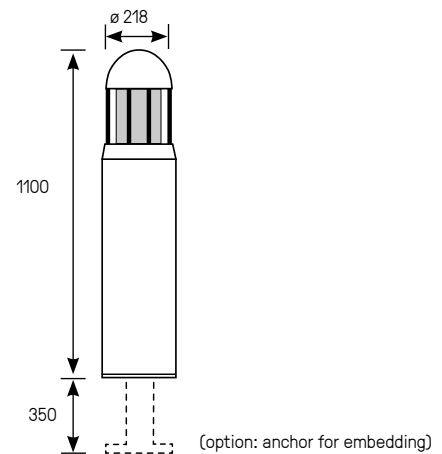
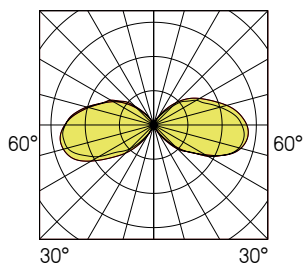

Power (W)	Luminaire light output (lm)	Luminaire efficacy (lm / W)	Code
28	1100	39	8500 2300

Lumen maintenance: L70B50 / 50,000 h

## DETAILS



