

Stainless steel TITAN COMPACT

A highly-compact architectural
LED luminaire for circulation
areas and public spaces
subject to vandalism.

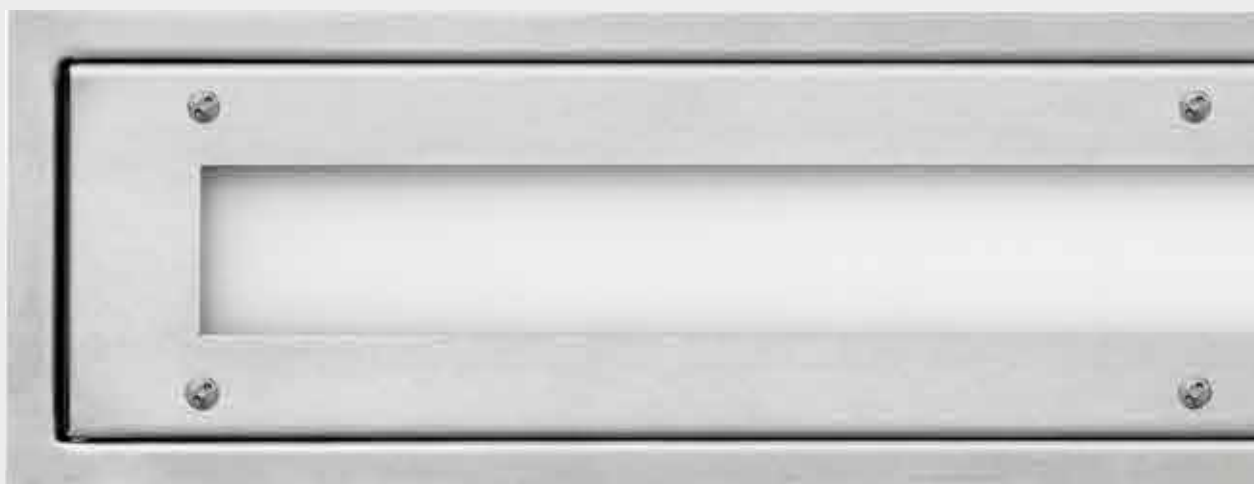

BVCert. 6037554





FEATURES:

- Luminaire withstands extreme vandalism
- Flush-mounting version
- 316L stainless steel body
- Brushed 316L stainless steel frame
- Flat opalescent polycarbonate diffuser
- CCT 4000 K, CRI min. 80
- Stainless steel vandal-resistant screws
- Supplied c/w cable seal

OPTIONS AVAILABLE ON REQUEST:

- 3000 K LEDs

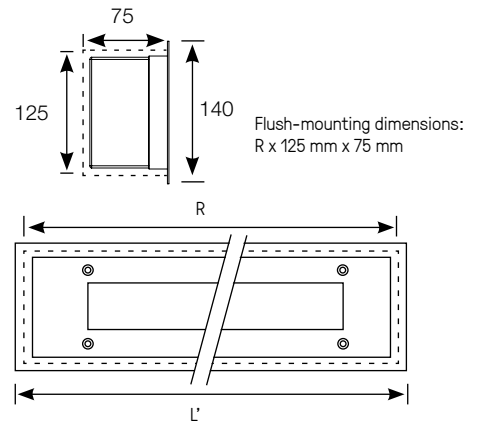
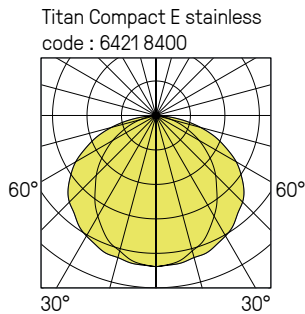

TITAN COMPACT E stainless

220-240 V AC / 50 / 60 Hz



direct 643

Aperture length R (mm)	Frame length L' (mm)	Power (W)	Luminaire light output (lm)	Luminaire efficacy (lm/W)	Code
390	405	11	800	73	6421 8400
675	690	21	1800	86	6422 8400
960	975	31	2750	89	6423 8400
1245	1260	43	3650	85	6424 8400

Lumen maintenance: L80B10 / over 72,000 h
L90B50 / 52,000 h

Coding colour temperature 3000 K :
replace 4 with 3

example 4000K : 6421 84--
3000K : 6421 83--

Vandal-resistant tool (bit) to be ordered separately
code : 9800 0003

ADDITIONAL OPTIONS TITAN COMPACT

Coding:
add the corresponding suffix to the product code

example : 6421 8400 ----
 9413 FLAT DUROFLAM® DIFFUSER
 9601 ANTI-GRAFFITI PROTECTION
 9702 STAINLESS STEEL CROSSPOINT SCREWS (VK54)

N.B. : through wiring possible on standard codes by piggy-backing on gear tray supply terminal block.